



better together



LIFTING STATIONS
FOR CIVIL WASTE
WATER

pump **BOX**

zenit.com

EN

Reaching the sewerage system that's too far away or at a higher level? With **pumpBOX** this is possible.

pumpBOX is a pre-assembled lifting station certified in accordance with EN 12050-1 and 12050-2 standards for collecting and pumping waste water from toilets, washrooms or kitchens into the sewer system when a gravity feed is not available or distances are too great.

pumpBOX combines a robust polyethylene tank with a single or dual Zenit pump, resulting in a complete system for collecting and lifting municipality sewage and grey water.

Compact, quiet and reliable, **pumpBOX** is ready to use and does not require excavation or masonry work.

The different configurations with one or two pumps, vortex or grinder type, give the **pumpBOX** a high degree of versatility and allow it to be used in a wide range of situations, from individual houses to residential complexes, from public buildings to shopping centres.



Why choose the **pumpBOX** solution?



Time

pumpBOX is supplied pre-wired and pre-assembled. All electrical and hydraulic connections are factory made and only need to be connected to the respective plants, with a significant reduction in installation time



Space

pumpBOX comprises tank, pump and fittings complete with check valves in a single, compact and rational system. No additional accessories are required to ensure a small footprint and optimal installation in any environment.



Costs

Opting for a single, complete product means optimising purchase costs, not only because of the avoidance of additional costs, but also because of the advantages of having a single commercial reference. Reducing the impact of installation, maintenance and transport on the project results in significant savings without affecting the quality of the end result.

Easy to install



Read the QR-code and watch the installation procedure!

Specifications

- PE tank, EN 12050-1, 12050-2 certified
- Rated volume 75 litres (GR version) or 115 litres (DG version)
- White colour for immediate verification of liquid level inside
- Strong one-piece construction with internal reinforcement feet
- Low-noise version (<70 dB), sealed against liquids and odours
- Large Ø 90 mm inspection window on top wall
- GR version (grinder pump) or DG version (vortex pump)
- Single or dual pump version
- Maintenance-free PVC fittings and check valves (GR version)
Double check valve in UNI flanged cast iron (DG version)
- Float for maximum level alarm as standard
- Automatic pump start/stop system via float or level sensor



Applications

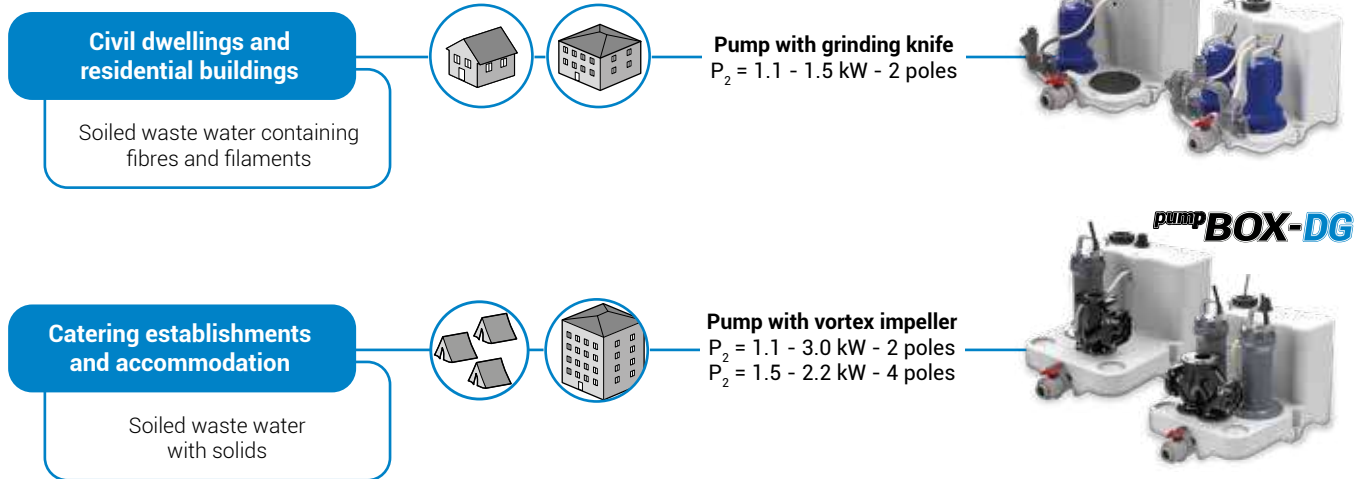

Modular "plug&play" structure



Metal structural work module that transforms the **pumpBOX** into a portable lifting station complete with control panel. Recommended for mobile and temporary installations for use at construction sites, public events, emergency situations. The steel structure makes it stackable for easy storage and transport.



Constructive details



- ① Thick polyethylene tank, tight to odours and liquids. Strong one-piece construction with internal reinforcement feet and floor fastening slots integrated into the casing.
- ② Internally shaped bottom to facilitate the suction of solids and reduce the accumulation of sediment that can generate bad odours and reduce the useful volume of the tank.
- ③ Emergency emptying valve in lowered position (ready for connection to optional hand pump).
- ④ PVC discharge unions and check valves (GR models). Cast iron double check valve with UNI flange (DG models).
- ⑤ Air venting system with activated carbon filter and ready for connection to external pipework DN40. The safety valve with float ensures a tight closure of the pipeline if the level rises and prevents possible liquid spillage.

- ⑥ Maximum level alarm via stainless steel float switch.
- ⑦ Pump start/stop device via pressure sensor or multiple contact float switch.
- ⑧ Prepared for inlet pipework from above or from side and rear walls (standard height: h 180, 250, 315 mm for direct connection to the WC). Gaskets Ø 75-110 mm, included.



Electrical control panel for managing the lifting station (available separately)

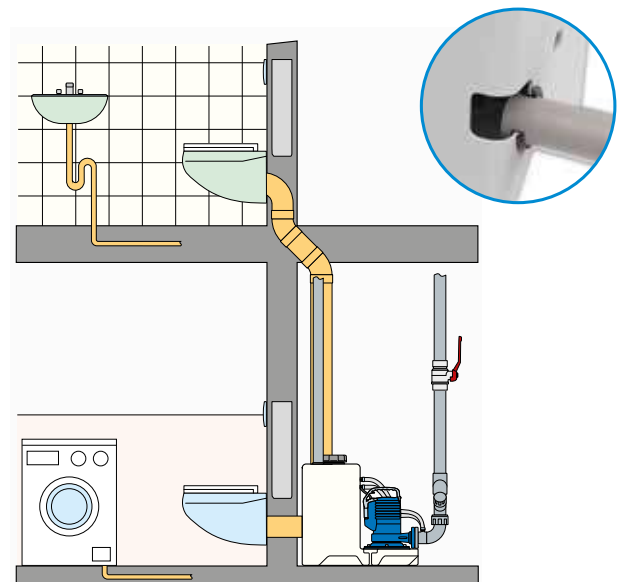

Automatic start/stop device

The pump is started and stopped by an automatic device that detects the liquid level in the tank.

The system can use a **pressure sensor** to be connected to a control panel or an innovative **multiple-contact float**.

In both cases, the device is housed inside the tank and can be removed through a large Ø 90 mm inspection window by unscrewing the locking ring nut of the watertight cover.

Pressure sensor

for constant detection of the liquid level and setting of the start/stop thresholds for the main and the secondary pump (if installed). Thanks to its wide reading range, it can use all the available volume while optimising operation.

It uses a standard 4-20 mA sensor.

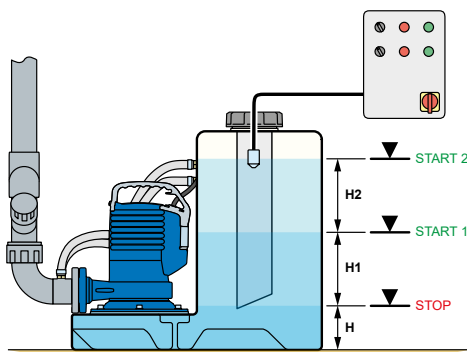

Multiple-contact float

for controlling with a single cable the start and stop of the main and the secondary pump (if installed) by means of internal contact closure, based on preset liquid level heights.

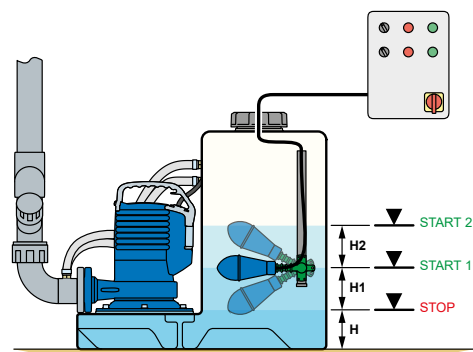

Pumping system

pumpBOX lifting stations can be equipped with grinding system or vortex type pumps, in single or dual configuration, depending on the type of waste water and the workload to be carried out.

All motors have two silicon carbide mechanical seals (SiC-SiC) in an inspectable oil chamber to give the system maximum reliability.

GR bluePRO pumps

Pumps with high head **grinder impeller** suitable for soiled waste water containing fibres and filaments.

Single-phase version supplied with ammeter protection and circuit breaker to ensure high starting torque and effective cutting action even during start-up.



Rotary knife

with three blades made of specially treated chrome steel for greater reliability when cutting solids.

DGG pumps

Vortex impeller pumps with full free passage suitable for use with soiled waste water with solids.



Free passage

the recessed vortex impeller and the internal shape of the tank ensure a wide free passage and smooth operation even in the presence of large solids.

Technical data and performance

<u>pumpBOX</u>	<u>DG</u>	<u>115S</u>	<u>150/2</u>	<u>M</u>
1	2	3	4	5

1 Product name
2 Installed pump type
3 Rated tank capacity (litres)
4 No. of pumps installed
5 Power (HPx100)/poles
6 Motor phases

V = vortex, GR = grinder
S = 1 (single), D = 2 (dual)
M = Single-phase, T = Three-phase

pumpBOX-GR

impeller with grinding knife

Model	no. / pumps	V/~ (50 Hz)	P ₂ (kW)/poles	Current (A)	Free flow (mm)	kg
1 pumpBOX GR 75S 150/2 M	1	230/1	1.1/2	7.5	-	59
1 pumpBOX GR 75S 150/2 T	1	400/3	1.1/2	3.2	-	59
2 pumpBOX GR 75S 200/2 T	1	400/3	1.5/2	4.3	-	61
1 pumpBOX GR 75D 150/2 M	2	230/1	1.1/2	7.5	-	84
1 pumpBOX GR 75D 150/2 T	2	400/3	1.1/2	3.2	-	84
2 pumpBOX GR 75D 200/2 T	2	400/3	1.5/2	4.3	-	88

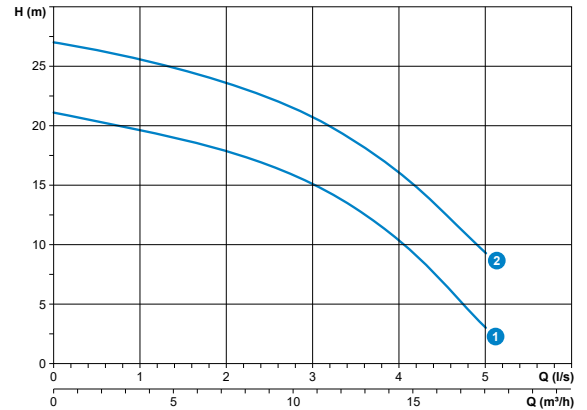

pumpBOX-DG

vortex impeller

Model	no. / pumps	V/~ (50 Hz)	P ₂ (kW)/poles	Current (A)	Free flow (mm)	kg
1 pumpBOX DG 115S 150/2 M	1	230/1	1.1/2	6.6	50	60.9
2 pumpBOX DG 115S 200/2 M	1	230/1	1.5/2	9.3	50	61.3
1 pumpBOX DG 115S 150/2 T	1	400/3	1.1/2	2.4	50	60.9
2 pumpBOX DG 115S 200/2 T	1	400/3	1.5/2	3.3	50	61.3
3 pumpBOX DG 115S 250/2 T	1	400/3	1.8/2	3.7	50	57.9
4 pumpBOX DG 115S 300/2 T	1	400/3	2.2/2	4.6	50	70.3
5 pumpBOX DG 115S 400/2 T	1	400/3	3.0/2	6.4	50	72.1
1 pumpBOX DG 115D 150/2 M	2	230/1	1.1/2	6.6	50	91.0
2 pumpBOX DG 115D 200/2 M	2	230/1	1.5/2	9.3	50	98.8
1 pumpBOX DG 115D 150/2 T	2	400/3	1.1/2	2.4	50	91.0
2 pumpBOX DG 115D 200/2 T	2	400/3	1.5/2	3.3	50	98.8
3 pumpBOX DG 115D 250/2 T	2	400/3	1.8/2	3.7	50	92.0
4 pumpBOX DG 115D 300/2 T	2	400/3	2.2/2	4.6	50	116.8
5 pumpBOX DG 115D 400/2 T	2	400/3	3.0/2	6.4	50	120.4

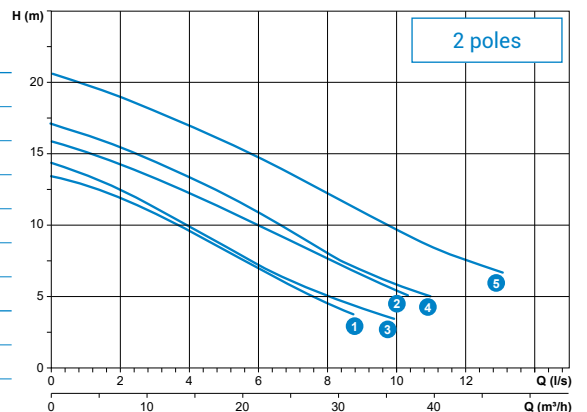

Model	no. / pumps	V/~ (50 Hz)	P ₂ (kW)/poles	Current (A)	Free flow (mm)	kg
1 pumpBOX DG 115S 200/4 T	1	400/3	1.5/4	3.4	45	72.8
2 pumpBOX DG 115S 250/4 T	1	400/3	1.8/4	4.3	45	75.6
3 pumpBOX DG 115S 300/4 T	1	400/3	2.2/4	5.2	45	75.6
1 pumpBOX DG 115D 200/4 T	2	400/3	1.5/4	3.4	45	121.3
2 pumpBOX DG 115D 250/4 T	2	400/3	1.8/4	4.3	45	126.9
3 pumpBOX DG 115D 300/4 T	2	400/3	2.2/4	5.2	45	126.9

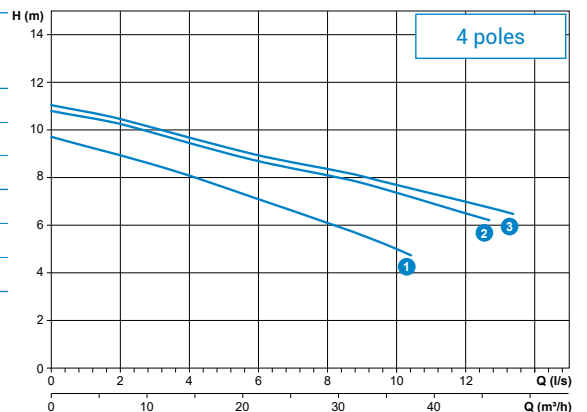

Dimensions

pumpBOX-GR - impeller with grinding knife - single pump version

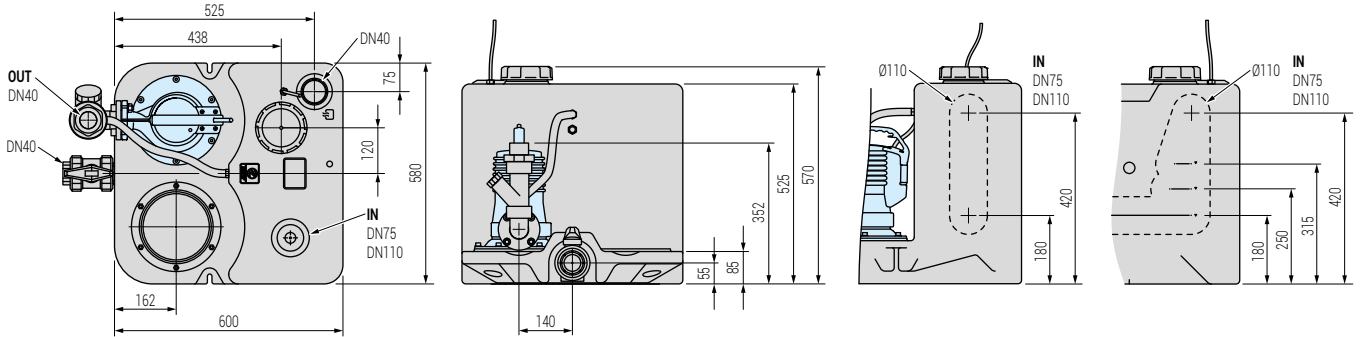

pumpBOX-GR - impeller with grinding knife - dual pump version

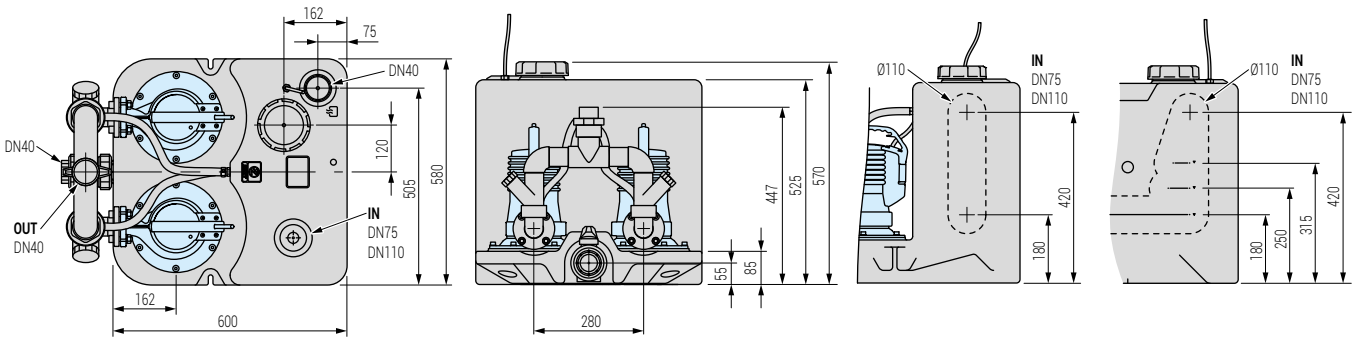

pumpBOX-DG - vortex impeller - single pump version

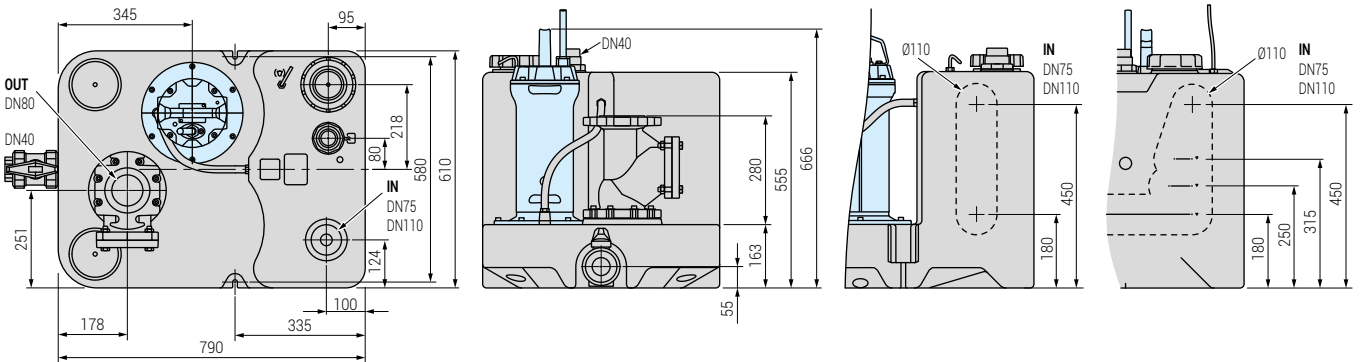

pumpBOX-DG - vortex impeller - dual pump version

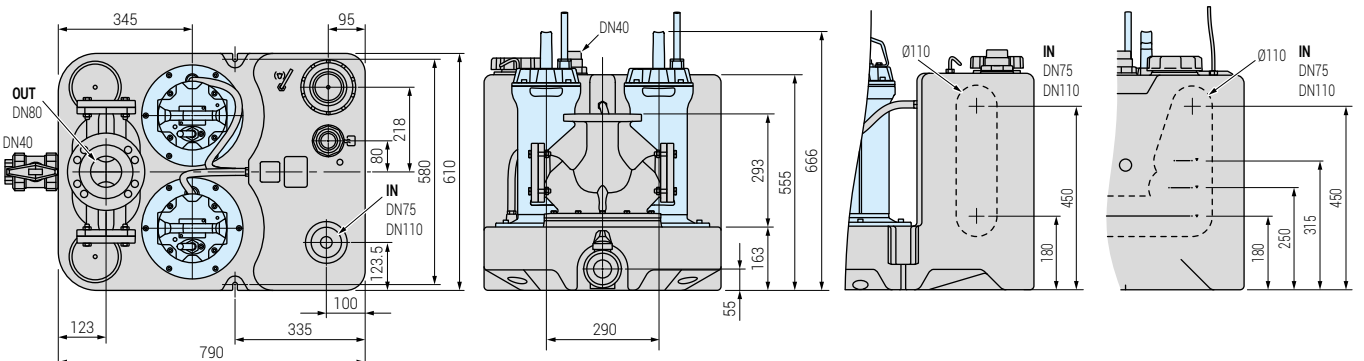



better together

The data is not binding.
Zenit reserves the right to make changes to the product without notice.

   For further information, please visit www.zenit.com

A digital version of this catalogue can be downloaded from the following address: www.zenit.com

Cod. 29040060780400000
Rev. 0 - 01/04/2022