



better together



COMPLETE SOLUTIONS  
FOR COLLECTION & LIFTING  
OF WASTE & DRAINAGE WATER

# Lifting Box

# Lifting **BOX** solutions

Our PE **lifting stations** are an effective solution for collecting and pumping wastewater and drainage water to the sewer system, when a gravity feed is not available or distances are too great. They are mainly used in rural or hilly areas with low population density, without an extensive municipal sewer system; or else following rezoning when connecting an area to the mains water network. Given their many advantages, lifting stations are today the best choice for a low cost, safe and eco-compatible solution.

## **DRAINAGE** Lifting BOX Solutions

- Flood Pump Kit
- nanoBOX
- blueBOX
  - 60
  - 90
  - 150
  - 250
  - 400
- vertiBOX
  - 85-120





better together

Zenit offers a complete range of modular lifting stations, available in different sizes and formats, suitable for all environments (domestic, residential, civil or industrial).

This range has been designed for collecting drainage water, rainwater, surface water and wastewater, and is supplied complete with piping, valves and installation accessories.

On request, they are available with level control float switches and electronic control panels.

**Lifting Box** models are designed to house Zenit submersible electric pumps with various hydraulics and power levels. The standard range can be supplemented with custom versions depending on the specific use.



## WASTEWATER *Lifting BOX* Solutions

### miniBOX

### blueBOX

- 60
- 90
- 150
- 250
- 400 - 400e

### SphereBOX

- 600
- 900
- 1200

### BOX PRO

- M
- V
- S
- J



# Flood Pump Kit



Our **Flood Pump Kit** comprises a DR steel pump and a discharge hose contained in a practical box.  
The quick fitting means the hose can be easily attached to the pump for quick intervention in emergencies.  
The incorporated float switch allows for automatic operation.  
All materials are corrosion resistant.

Ideal for emergency drainage/pumping out of cellars, garages, basements, and all environments subject to flooding.

## Benefits

- Everything required is contained within a box which can also act as a filter during operation
- Always ready for use



## Contents

- DR steel pump**  
with steel channel impeller and mechanical seal in oil chamber.  
Free passage max 10 mm.
- Discharge hose**  
Ø2", 10 m long hose with quick fittings.
- Accessories**  
Fittings and float switch support.

## Specifications

Pump	1x DR steel 25
Control system	Automatic with float switch/manual
Cable	10 m with Schuko plug
Discharge pipe	Ø 2" - 10 m
 Weight	12 kg

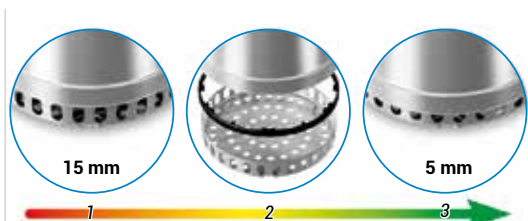
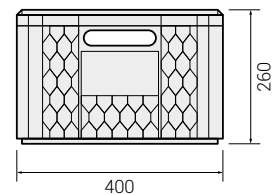
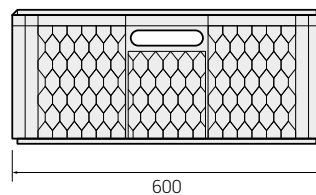

The **DR steel** easily converts from an ordinary submersible pump to a *dry floor* unit.  
When operating in this mode, the suction level can be reduced to as little as **5 mm** above the ground.

## Pump Specifications

	Impeller type	V/~	P2 [kW]	A	Ø	Free passage
<b>DR steel 25 M50</b>	Channel type	230/1	0.25	2.3	G 1 1/4"	10 mm

# nanoBOX



**nanoBOX** is a high-quality PE lifting station with a maximum capacity of 33 litres, supplied with a pre-installed DR *steel* stainless-steel pump. Thanks to its construction and small footprint, *nanoBOX* is very versatile and easy to install.

Can be used for collecting and lifting clear wastewater and grey water from domestic drains, including showers, sinks, washing machines and dishwashers (not suited for WCs).

## Benefits

- Pre-installed pump
- Automatic control system with start/stop float switch
- Compact size



## Contents

**DR steel pump**  
with steel channel impeller and mechanical seal in oil chamber.  
Free passage max 10 mm.

## Specifications

Capacity (l)	33
Tank material	PE
Installation	External
Pump	1 x DR steel 37
Control system	Automatic with float switch
Cable	10 m with Schuko plug
Discharge	Ø 2"
 Weight	8.7 kg

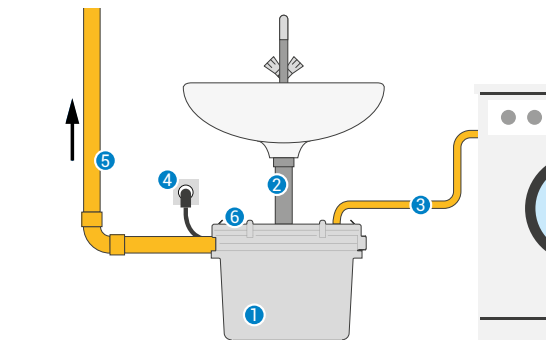

1. nanoBOX
2. Sink drain inlet [with siphon]
3. Washing machine drain inlet
4. Power supply
5. Discharge pipe
6. Breather outlet with activated carbon filter.  
Can be connected to external breather pipe [optional]

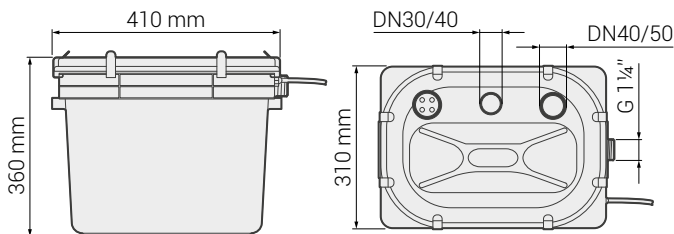

## Pump Specifications

	Impeller type	V/~	P2 [kW]	A	Ø	Free passage
<b>DR steel 37 M50</b>	Channel type	230/1	0.37	3.1	G 1 1/4"	10 mm



# blueBOX



**blueBOX** lifting stations are extremely versatile and easy to install. The 60, 90, 150 and 250 litre models are equipped to house a DR steel 37 stainless-steel pump with channel impeller. The 400 litre model, designed mainly for civil plant installations, is equipped with a DR steel 55 pump for maximum reliability, even in demanding usage situations. They can be used for collecting and lifting rainwater and seepage water, as well as clear wastewater and grey water of civil plant and domestic origin.

## Benefits

- Wide range of models, versatile and easy to install
- Provision for inlets up to DN110
- Suitable for indoor or outdoor installation



### Cover

Rugged walk-over cover with gasket. The large cover allows a second pump to be added in emergencies, for easy, hygienic drainage.



### Handles

Two integral handles for lifting and transport, for easy transfer by hand.



### Inlets

Wastewater pipe intake ports also provided on sides.

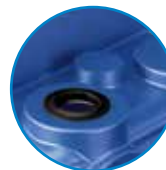

### Gaskets

Guaranteed watertight thanks to NBR rubber gaskets which allow quick connection of pipes to the blueBOX with no need for sealants.

## Contents



### DR steel pump

with steel channel impellers and mechanical seal in oil chamber. Free passage max 10 mm.

(Supplied, installation is customer responsibility)



### Pre-installed PVC hydraulic accessories

- Ball check valve
- Gate valve
- Connecting pipe

(Accessories may vary depending on configuration)







## Optional



### Electronic control panel

with self-learning for direct starting of single- and three-phase pumps and protection against dry running via  $\phi$  and minimum current.

## Specifications

	<b>blueBOX 60</b>	<b>blueBOX 90</b>	<b>blueBOX 150</b>	<b>blueBOX 250</b>	<b>blueBOX 400</b>
					
Capacity [l]	60	90	150	250	400
Tank material	PE				
Installation	Surface				
Pump	DR steel 37				DR steel 55
Control system	Automatic with float switch				
Cable	10 m with Schuko plug				
Discharge	G1¼"	G1¼"	G1½"	G1½"	G1½"
 (tank only)	8.0	9.0	11.0	15.0	31.0

**blueBOX 60-90-150**

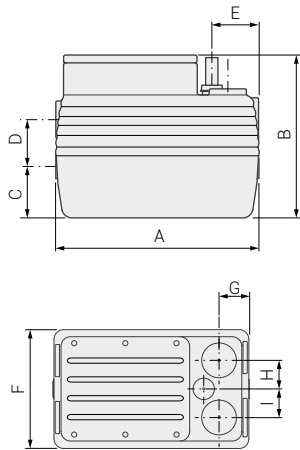

**blueBOX 250**

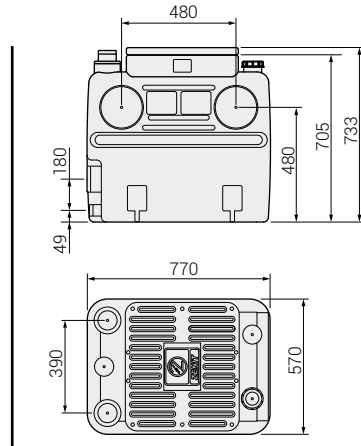

**blueBOX 400**

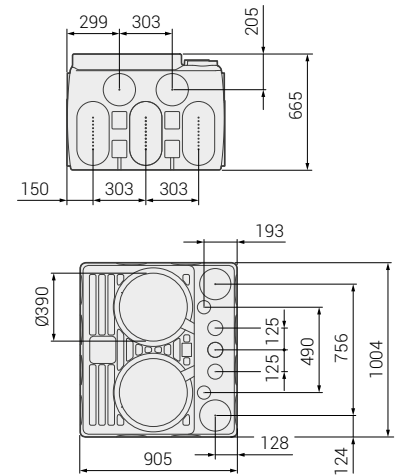

	A	B	C	D	E	F	G	H	I
<b>blueBOX 60</b>	480	400	80	200	95	370	90	110	80
<b>blueBOX 90</b>	480	610	140	210	65	480	85	115	90
<b>blueBOX 150</b>	580	660	140	260	150	480	85	120	120

## Pump Specifications

	Impeller type	V/~	P2 [kW]	A	Ø	Free passage
<b>DR steel 37 M50</b>	Channel type	230/1	0.37	3.1	G 1¼"	10 mm
<b>DR steel 55 M50</b>	Channel type	230/1	0.55	4.3	G 1½"	12 mm

# vertiBOX



vertiBOX lifting stations can be used in a wide range of situations thanks to their modular structure, which allows the installation to be optimised for the specific usage.

They are equipped to house a DR steel / 37 stainless-steel pump with channel impeller.

They are ideally suited for collecting and lifting clear wastewater and grey water in residential environments, rainwater from car parks or courtyards, and in small civil plant situations for transferring drainage water and seepage water.

## Benefits

- Modular structure, from 300 to 800 litres
- Walk-over or drive-over cover (B class)
- Provision for intake pipes from DN 50 to DN 200



### Cover

Rugged walk-over cover or drive-over cover hermetically sealed with a gasket, with safety closure and inspection window.

A telescopic system allows its height to be adjusted to suit any type of installation.

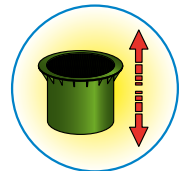

### Structure

Tough PE construction with reinforcement ribs guaranteeing durability and effective anchoring to the ground.



### Inlets

Provision for intake pipes from DN 50 to DN 200 NBR gaskets to seal off liquids and odours.

Holes can be cut on site using a normal holesaw of appropriate diameter.



### Discharge

Discharge pipe in PVC with G1 1/4 threaded union.

## Contents



### DR steel pump

with steel channel impeller and mechanical seal in oil chamber. Free passage max 10 mm.

(Supplied, installation is customer responsibility)



### PVC hydraulic accessories

- Ball check valve
- Gate valve
- Connecting pipe

(Accessories may vary depending on configuration)

## Optional



### Electronic control panel

with self-learning for direct starting of single- and three-phase pumps and protection against dry running via  $\phi$  minimum current.



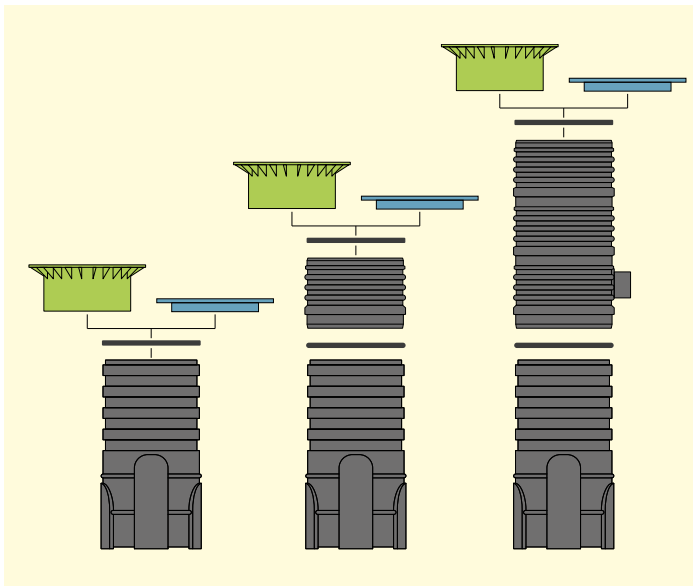

## A modular solution

- vertiBOX** can incorporate
- BASE module
  - 400 mm riser
  - 1210 mm riser
  - WALK-OVER or DRIVE-OVER cover (B class)

All component joints are watertight thanks to the use of tough lip seals.

The perfect compatibility of the components means it is possible to create made-to-measure solutions which meet requirements for collecting and lifting water in the best possible manner; this makes them ideal for a wide range of applications, from domestic and residential through to civil plant and industrial.

All BASE modules can be cut to a height of 850 mm if required, reducing their capacity to 300 litres while maintaining complete compatibility with all the other components in the range.

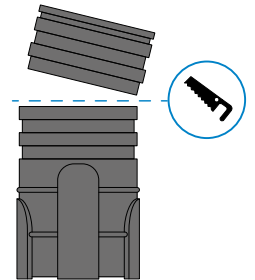

## Specifications

<b>vertiBOX 85-120 (BASE module)</b>	
Capacity (l)	300 (h850 mm) - 420 (h1200 mm)
Tank material	PE
Installation	Surface, underground
Pump	1 x DR steel 37
Cable	10 m with Schuko plug
Discharge	G1¼"
 (tank only)	18

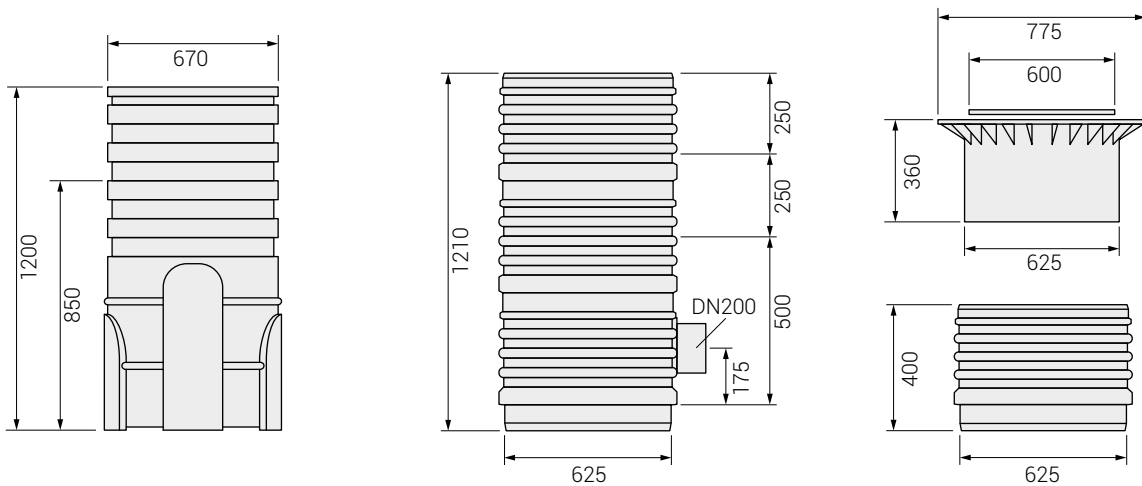

## Pump Specifications

	Impeller type	V/~	P2 [kW]	A	Ø	Free passage
<b>DR steel 37 M50</b>	Channel type	230/1	0.37	3.1	G 1¼"	10 mm

# Wastewater BOX Solutions



# miniBOX



**miniBOX** makes it possible to create a bathroom in any part of a house, even if it is a great distance from the soil stack or below the invert level of the drain.

**miniBOX** is able to grind all waste and pump it through normal diameter pipes to the soil stack.

It is composed of a PE tank with a GR steel pump with grinder inside it, and can be installed directly behind the toilet, for significant space savings. The cable with plug can be connected to a normal power socket, meaning an electrician is not required for the installation.

**miniBOX** is suitable for collection and lifting of domestic black water and grey water from toilets or bidets.



## Benefits

- Compact and quiet
- Two models with front or side inlet
- Automatic control system with internal start/stop float switch

## Specifications

Capacity (l)	6
Tank material	PE
Installation	External, wall
Pump	GR steel
Control system	Automatic with float switch
Cable	1.5 m with Schuko plug
Discharge	DN32/DN40
 kg	13.5 kg



### Grinder

Pump with anti-clogging system incorporating rotating chopper knife

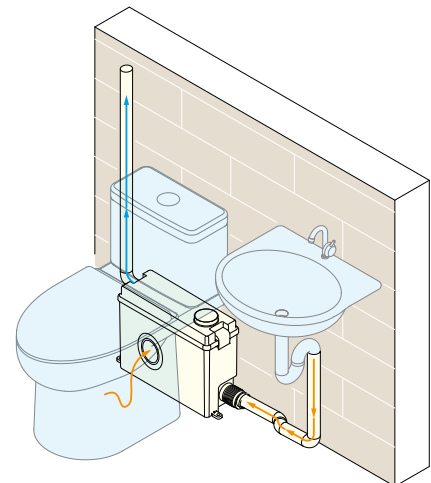
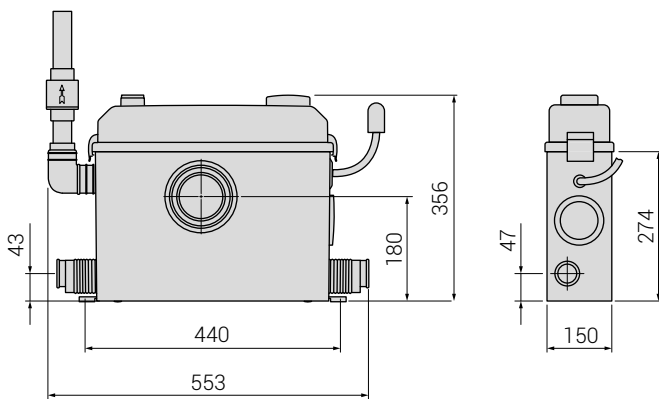

## Pump Specifications

	Impeller type	V/~	P2 [kW]	A	Ø	Free passage
<b>GR steel 37 M50</b>	With grinder	230/1	0.37	3.1	G 1 ¼"	-

# blueBOX



**blueBOX** lifting stations feature a wide range of models to meet even the most demanding installer's requirements. The 60, 90 and 150 litre models are equipped to house a DG *steel* stainless-steel pump with vortex impeller. The 250 and 400 litre models can be equipped with three different kinds of pumps, depending on usage: DG *steel* stainless-steel pump with vortex impeller, DG *bluePRO* cast-iron pump with vortex impeller, or GR *bluePRO* cast-iron pump with grinding system. The 400 *Double* version allows the installation of two *bluePRO* series pumps with vortex impeller or grinder for maximum efficiency and reliability. They are suitable for collecting and grey water and sewage of domestic and residential origin from toilets and washing machine outlets, and wastewater with solids and fibres.

## Benefits

- Wide range of models, versatile and easy to install
- Provision for inlets up to DN110
- Suitable for indoor or outdoor installation



### Cover

Rugged walk-over cover with gasket. The large cover allows a second pump to be added in emergencies, for easy, hygienic drainage.



### Handles

Two integral handles for lifting and transport, for easy transfer by hand.



### Inlets

Wastewater pipe intake ports also provided on sides.

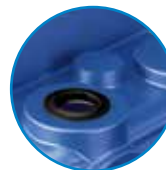

### Gaskets

Guaranteed watertight thanks to NBR rubber seals which allow quick connection of pipes to the *blueBOX* with no need for sealants.

## Contents



DG *steel*



DG *bluePRO*



GR *bluePRO*

### Submersible pump (3 versions)

- Stainless steel with vortex impeller (DG *steel*)
- Cast iron with vortex impeller (DG *bluePRO*)
- Cast iron with grinder (GR *bluePRO*)

(Supplied, installation is customer responsibility)



### PVC hydraulic accessories

- Ball check valve
- Gate valve
- Connecting pipe

(Accessories may vary depending on configuration)







## Optional



### Electronic control panel

with self-learning for direct starting of single- and three-phase pumps and protection against dry running via  $\phi$  minimum current.

## Specifications

	<i>blueBOX 60</i>	<i>blueBOX 90</i>	<i>blueBOX 150</i>	<i>blueBOX 250</i>	<i>blueBOX 400</i>	<i>blueBOX 400 Double</i>
						
Capacity [l]	60	90	150	250	400	400
Tank material	PE					
Installation	Surface					
Pump	DG steel 37	DG steel 37	DG steel 55	DG steel 55 DG bluePRO 150 GR bluePRO 200	DG steel 55 DG bluePRO 150 GR bluePRO 200	2x DG steel 55 2x GR bluePRO 200
Control system	Manual/automatic with float switch					
Cable	10 m					
Discharge	G1¼"	G1¼"	G1½"	G1½" - G2"	G1½" - G2"	G1½" - G2"
 (tank only)	8.0	9.0	11.0	15.0	31	31

*blueBOX 60-90-150*

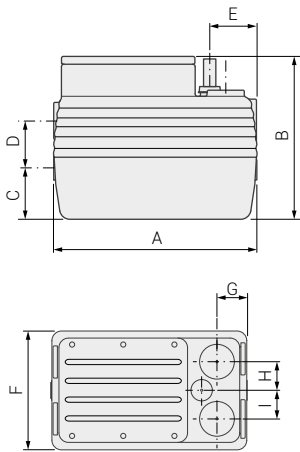

*blueBOX 250*

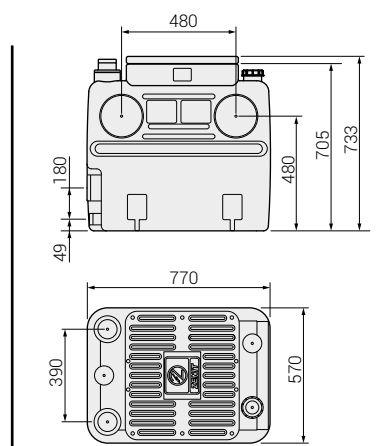

*blueBOX 400*

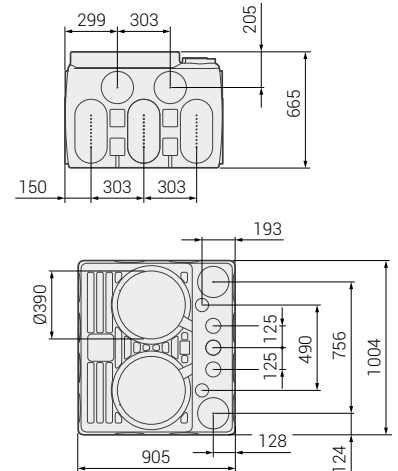

	A	B	C	D	E	F	G	H	I
<i>blueBOX 60</i>	480	400	80	200	95	370	90	110	80
<i>blueBOX 90</i>	480	610	140	210	65	480	85	115	90
<i>blueBOX 150</i>	580	660	140	260	150	480	85	120	120

## Pump Specifications

	Impeller type	V/~	P2 [kW]	A	Ø	Free passage
<b>DG steel 37 M50</b>	Vortex	230/1	0.37	3.1	G 1¼"	25 mm
<b>DG steel 55 M50</b>		230/1	0.55	4.3	G 1½"	40 mm
<b>DG bluePRO 150/2/G50V A1CM5</b>		230/1	1.1	7.5	G2"	50 mm
<b>DG bluePRO 150/2/G50V A1CT5</b>		400/3	1.1	3.2	G2"	50 mm
<b>GR bluePRO 200/2/G40H A1CM5</b>	With grinder	230/1	1.5	10	G 1½" - DN32	-
<b>GR bluePRO 200/2/G40H A1CT5</b>		400/3	1.5	4.3	G 1½" - DN32	-

# blue BOX400<sub>e</sub>



The **blueBOX 400e** lifting station is extremely tough and reliable. Its large 400 litre capacity and the possibility to install multiple coupled units allows its use in residential and industrial locations of significant size.

When high flow rates are required, **blueBOX 400e** can be equipped with two external **UNIQA** series pumps which can be managed with alternate operation via a dedicated electrical control panel.

It can be used for collecting and lifting grey water and black water of civil and industrial origin, for disposal of wastewater with solids and fibres, and for transferring drainage from public establishments to the sewer system.

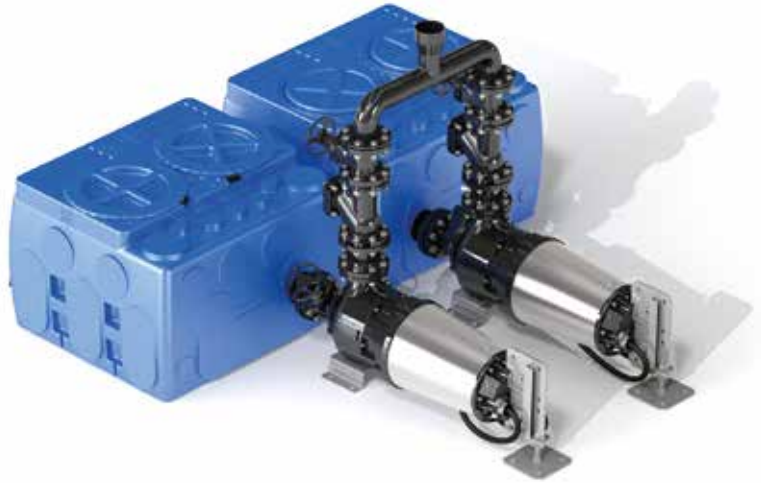

## Benefits

- High capacity
- Can be installed in pairs
- Use with high-efficiency UNIQA series pumps

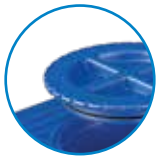

**Cover**  
Rugged walk-over cover with screw fastening, safety lock and twin O-rings.



**Fixing**  
Slots for floor mounting and integrated handles for manual movement.



**Emergency emptying**  
Emergency drainage fitting located low down in the unit in the event of prolonged blackouts.

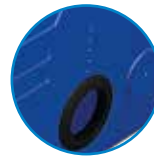

**Gaskets**  
Watertight seal between pipes and **blueBOX** assured by NBR rubber gaskets. No additional sealants are required.

## Specifications

<b>blueBOX 400e</b>	
Capacity [l]	400 per unit. Can be installed in pairs
Tank material	PE
Installation	Surface
Recommended pump	Compatible with <b>UNIQA</b> models
Control system	Manual/automatic with float switch
(tank only)	15.0

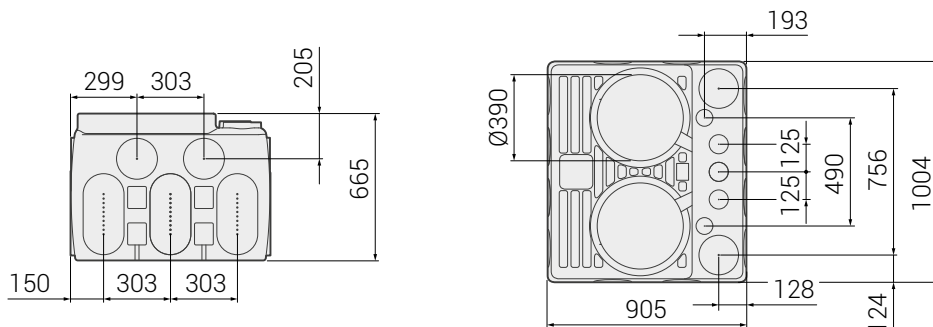



# sphereBOX



The **sphereBOX** lifting station incorporates various modular components allowing a custom composition which adapts to the needs of users. As well as the different tank capacities, it is also possible to choose the type of internal installation, the most suitable riser and the type of cover (walk-over or drive-over version).

Use with *bluePRO* or *Grey* pumps with 2" discharge recommended.

Can be used for collecting and disposing of heavily soiled wastewater of civil origin, sewage and industrial wastewater.

## Benefits

- Range includes 600, 900 and 1200 litre models
- Modular components for optimised installation
- Provision for pumps with 2" discharge outlets



### Cover

Tough cover, hermetically sealed with safety closure and inspection window.

Available in walk-over or drive-over version.

Height can be adjusted to suit any type of installation.

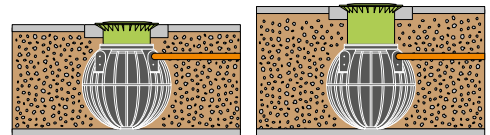

### Risers

Two different riser types can be used, simplifying installation even in existing systems.



### Structure

Tough PE construction with reinforcement ribs guaranteeing durability and effective anchoring to the ground.

## Contents



### PVC hydraulic accessories

- Ball check valve
- Gate valve
- Connecting pipe

(Accessories may vary depending on configuration)

## Recommended pumps

The *sphereBOX* lifting station can be equipped with pumps with 2" discharge outlets.

Zenit recommends **bluePRO** and **Grey** series pumps with vortex impeller (DG *bluePRO*, DGG) or with grinding system (GR *bluePRO*, GRG).



## Optional



### Electronic control panel

with self-learning for direct starting of single- and three-phase pumps and protection against dry running via  $\phi$  minimum current.



## A modular solution

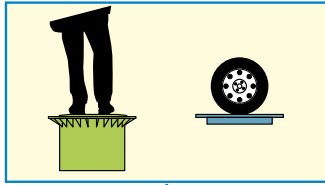

**Cover.** Walk-over or drive-over cover, Ø 600 mm, compatible with all *sphereBOX* and *vertiBOX* models  
Adjustable height with hermetic seal.  
Vehicle loading version (class B) with cast iron cover.

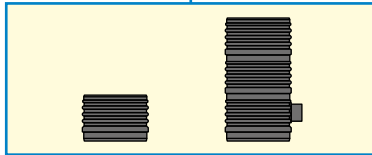
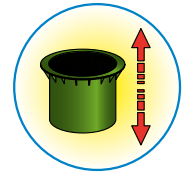

**Optional riser**  
Ø600 mm  
h 400 - 1210 mm

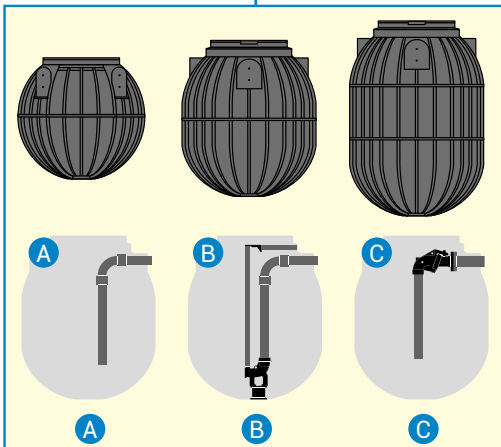

**Tank** 600 / 900 / 1200 litre  
can be installed in the following ways:

- (A) Fixed** with ball valve, gate valve, and 1 ¼" PVC connecting pipe for 1 pump
- (B) with vertical discharge bottom coupler**, ball valve and 2" PVC connecting pipe for 1 pump
- (C) with DAC E external coupler**, ball valve and 2" PVC connecting pipe for 1 pump (2 pumps only for sphere BOX 1200 model)

## Specifications

	<i>sphereBOX</i> 600	<i>sphereBOX</i> 900	<i>sphereBOX</i> 1200
Capacity [l]	600	900	1200
Tank material	PE		
Installation	Underground		
Recommended pump	<i>bluePRO</i> series - Grey series		
Discharge	1 ¼" - 2"		
 (tank only)	27	47	58

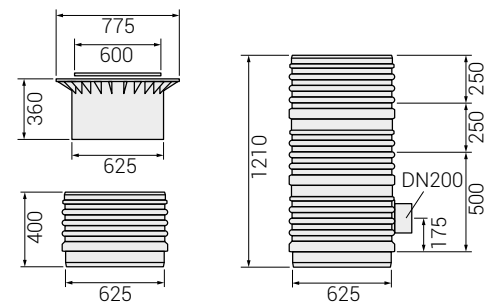

	A	B	C	D	E	F
<i>sphereBOX</i> 600	1045	-	790	890	1125	645
<i>sphereBOX</i> 900	1345	545	1005	1105	1155	645
<i>sphereBOX</i> 1200	1670	545	1330	1430	1155	645

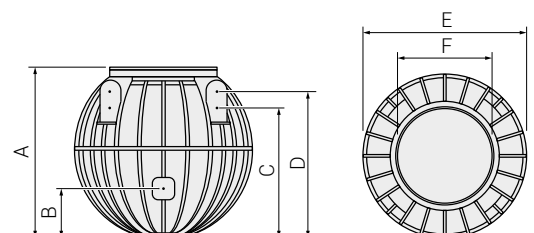

# BOX<sup>PRO</sup>



The **BOX PRO** range comprises tough PE lifting stations with capacities ranging from 1,000 to 18,000 litres. These stations are specially shaped to resist the pressure to which they are subject once installed. Their smooth inner walls prevent the formation of encrustations which can lead to a reduction in volume and be a cause of bad odours, as well as ensuring optimal performance. BOXPRO can be equipped with one or two pumps installed with a bottom coupling system. Zenit recommends the use of float switches connected to an electrical control panel for managing start, stop and alarm levels. They are designed mainly for collection and lifting of wastewater with solids and sewage of civil and industrial origin, including systems of significant size.

## Benefits

- Extensive range from 1,000 to 18,000 litres
- Drive-over metal cover
- Reduced positioning and installation times



### Structure

In thick PE with better resistance to low temperatures. Rugged polypropylene walk-over cover as standard.



### Ground

All metal parts inside the lifting stations are connected to an electrical grounding circuit.



### Check valves

Ball check valves always included in standard supply package

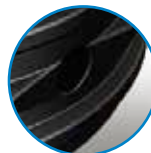

### Intake pipe

Designed for connection of intake pipe Ø110 or Ø160 mm in the bottom of the lifting station to reduce turbulence. Joint with gasket to prevent leaks or escaping odours.

## Contents



### PVC hydraulic accessories

- Ball check valve
- Gate valve
- Connecting pipe

(Accessories may vary depending on configuration)

## Recommended pumps

For the BOXPRO range of lifting stations, Zenit recommends **Grey** and **UNIQA** series pump models with vortex impeller (DGG, ZUG V) or grinding system (GRG, ZUG GR).



## Optional



### Electronic control panel

with self-learning for direct starting of single- and three-phase pumps and protection against dry running via  $\phi$  minimum current.

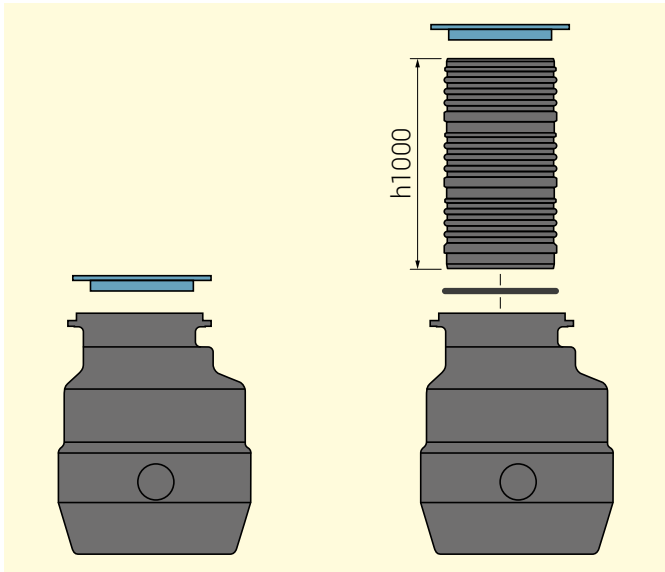





### Maximum versatility

The **BOX PRO M** 1000-litre model can be used both on its own and with a 1000 mm riser.

This allows the lifting station to be easily adapted to existing systems.

The Ø 800 mm cover is available in walk-over or drive-over version, depending on user requirements.

### Specifications

	BOX PRO M	BOX PRO V	BOX PRO S	BOX PRO J
				
Capacity [l]	1000	2000	4000÷9500	10,000 - 18,000
Tank material	PE			
Installation	Underground			
Recommended pump	Grey series - UNIQA series			
 (tank only)	85	134	242 ÷ 839	422 ÷ 1508

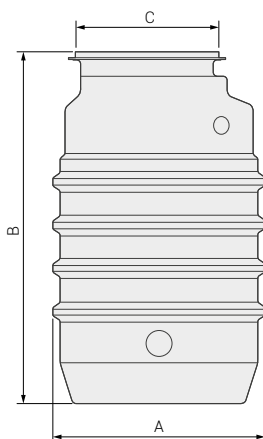

	A	B	C
<b>BOX PRO M</b>	1140	1326	Ø800
<b>BOX PRO V</b>	1016	2310	600
<b>BOX PRO S</b>	1624	2015 ÷ 4500	800
<b>BOX PRO J</b>	2246	2520 ÷ 4500	1000



# Supplied pump specifications

## DRAINAGE BOX Solutions

	Impeller type	V/~	P2 [kW]	A	Rpm	Ø	Free passage
1	DR steel 25/2 M50	230/1	0.25	2.3	2900	G 1¼"	10 mm
2	DR steel 37/2 M50	230/1	0.37	3.1	2900	G 1¼"	10 mm
3	DR steel 55/2 M50	230/1	0.55	4.3	2900	G 1½"	12 mm

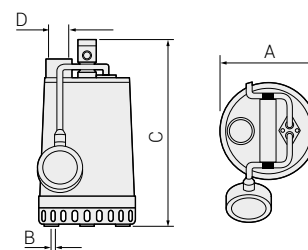
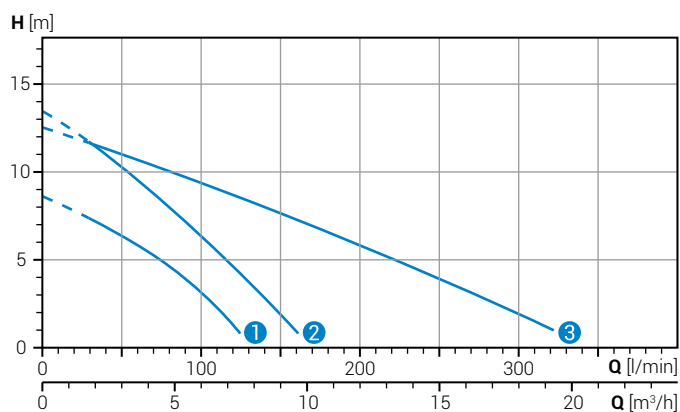

	A	B	C	D	kg	
1	DR steel 25/2 M50	170	10	300	G 1¼"	5.9
2	DR steel 37/2 M50	170	10	300	G 1¼"	6.3
3	DR steel 55/2 M50	215	12	335	G 1½"	7.7

## WASTEWATER BOX Solutions

	Impeller type	V/~	P2 [kW]	A	Rpm	Ø	Free passage
1	DG steel 37/2 M50	230/1	0.37	3.1	2900	G 1¼"	25 mm
2	DG steel 55/2 M50	230/1	0.55	4.3	2900	G 1½"	40 mm
3	DG steel 75/2 M50	230/1	0.75	4.3	2900	G 1½"	40 mm

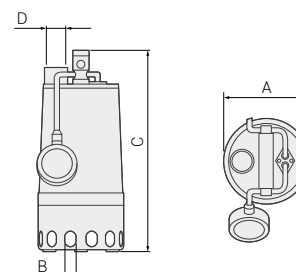
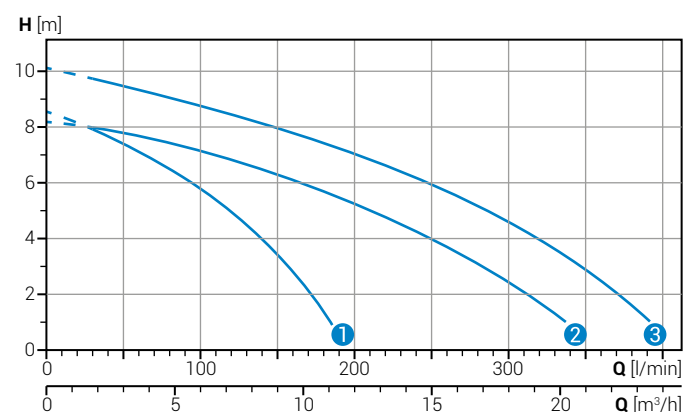

	A	B	C	D	kg	
1	DG steel 37/2 M50	170	20	350	G 1¼"	6.6
2	DG steel 55/2 M50	170	40	400	G 1½"	8.1
3	DG steel 75/2 M50	210	40	400	G 1½"	8.9



better together



	Impeller type	V/~	P2 [kW]	A	Rpm	Ø	Free passage	
1	DG bluePRO 150	Vortex	230/1	0.25	2.3	2900	G 1 ¼"	50 mm
2	GR bluePRO 200	With grinder	230/1	0.55	4.3	2900	G 1 ½"	-

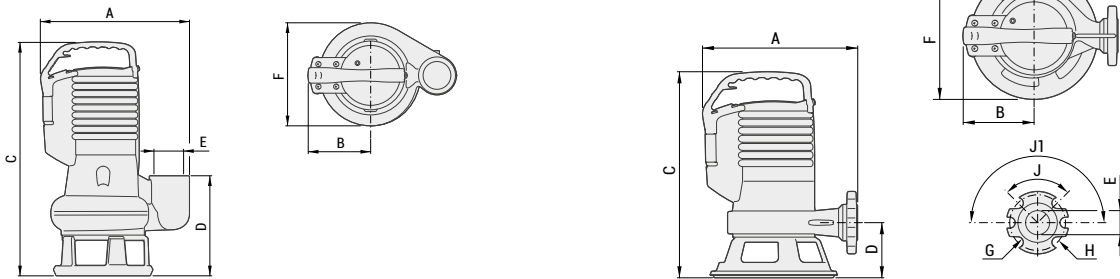
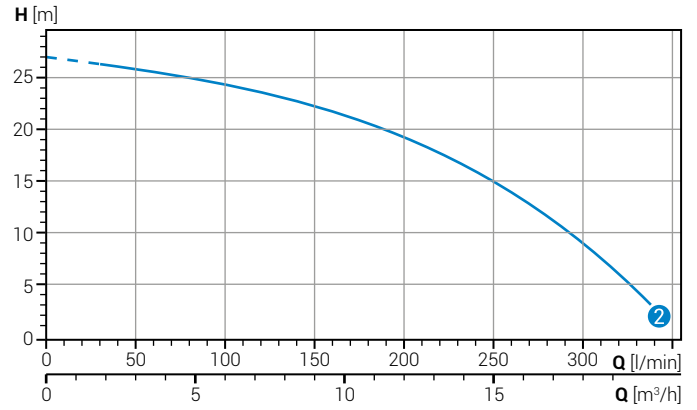
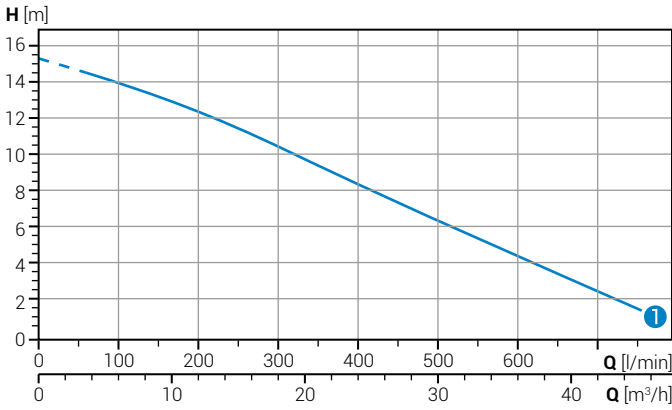

	A	B	C	D	E	F	kg	
1	DG bluePRO 150	295	125	465	195	G2"	200	23.0
2	GR bluePRO 200	285	125	410	100	G 1 ½"	230	26.0

Recommended pumps for **blue BOX400<sub>e</sub>** **sphere BOX** **BOX<sup>PRO</sup>**

series  
**Grey**



series  
**UNIQA**



**zeno**  
NAVIGATOR SUITE

The technical **Data Booklet** complete with duty curves is available for download in the download area of **zenit.com**

To select the pump best suited to your needs we advise you to use the **Zeno Pump Selector** configuration tool on the **zenit.com** website

# Zenit Group

Today the Zenit Group ranks among the top Italian and international names in the design and manufacture of submersible electric pumps for domestic, civil and industrial use, and water treatment systems.

With the know-how and experience acquired over the years, Zenit offers the market a comprehensive range of products designed to meet the most demanding needs.



**Modena**  
Italy



**Bascharage**  
Luxembourg



**Suzhou**  
China



**Singapore**  
Singapore

WE STRIVE TO BE A VALUABLE PARTNER  
YOU CAN TRUST IN YOUR SEARCH FOR  
WATER TREATMENT SOLUTIONS AND  
SERVICES.

## Our organisation

**Zenit** is a modern industrial organisation with a workforce of over 250 and four locations worldwide, that manages its markets directly and with success, thanks to extensive market coverage.

This international expansion is driven by our desire to serve our customers better with closer proximity.

Each **Zenit** group company has its own organisation, but they all operate in pursuit of a single mutual objective. Our origin as a family business has enabled us to stay streamlined and flexible, quick to respond with effective solutions.





Come and visit us at  
**[www.zenit.com](http://www.zenit.com)**



better together



**HEAD OFFICES**  
1 Pindou Str. & 17 Poseidonos ave.  
GR-18344 Moschato, Athens, Greece  
Tel.: +30 210 94 29 993 - Fax: +30 210 94 29 559  
E-mail: info@roi.gr

**MACEDONIA BRANCH**  
15 5 lia\_ monStg.  
GR-)4\* & 6 aloniW Greece  
Tel.: +30 2 10 ) & + ) - Fax: +30 2 10 ) & + )  
E-mail: h \ \ Y gng\_# roi.gr

**THESSALY BRANCH**  
159 Volou Str.  
GR-41336 Larisa, Greece  
Tel. - Fax: +30 2410 ) 1 494  
E-mail: larisa@roi.gr

**CRETE OFFICE**  
Tel. - : at +30 28210 88053  
E-mail: kriti@roi.gr

**WAREHOUSE, PRODUCTION, SERVICE**  
37 Pireos Str.,  
GR-18344 Moschato, Athens, Greece  
Tel.: +30 210 4, 3s 33) - Fax: +30 210 48 22 406  
E-mail: service@roi.gr